

PURE POWER[®]



PPAC2026 AIR COMPRESSOR **OPERATOR'S MANUAL**



PUREPOWEREQUIPMENT.COM

INTRODUCTION	3
SAFETY OVERVIEW	4
INSTALLATION AND GROUNDING	7
ASSEMBLY	8
COMPONENT DIAGRAM	9
OPERATION	10
MAINTENANCE	10
TROUBLESHOOTING	11
WARRANTY	12
NOTES	13

SPECIFICATIONS

ITEM	RATING
Running Horsepower	2.0 HP
Voltage	120
Running Amps	14.2
Cord Length	6'
Maximum Air Pressure	125 PSI
CFM @ 40 PSI	4.8
CFM @ 90 PSI	3.8
Lubrication	Oil lubricated
Tank Size	26 Gallon

Congratulations on your purchase of a Pure Power Equipment air compressor. You can be confident that this machine is constructed and tested with optimum performance and quality in mind.

Reading this manual will help get you the best results for set-up, operation, maintenance and avoid personal injury or damage to your machine. By knowing how best to operate this machine, you will be better positioned to show others who may also operate the unit.

All the information in this manual is based on the latest product information available at the time of printing. Pure Power Equipment reserves the right to make changes at any time without notice or incurring any obligation.

Owner/Operator Responsibility

The owner/operator must have a thorough understanding of the operation, maintenance and dangers associated with using this machine. It must be understood that it is ultimately up to the owner/operator to safely use this machine as outlined in this manual.

This manual is considered a part of the machine and needs to be kept in a safe location. If the machine is resold or given to someone else, this manual needs to be included.

Product Registration

Please register your product online to get the maximum benefit from your warranty. Use the QR code below or register online at: <https://www.purepowerequipment.com/register-product/>



It is recommended that you record the product identification numbers in this manual. These numbers are important to have on hand if you need to contact technical support (**1-866-850-6662**). The model and serial number can be found on the box and on a decal on the machine.

PRODUCT IDENTIFICATION

Model Number: _____

Serial Number: _____

Date of Purchase: _____

Dealer Name _____

SAVE THESE INSTRUCTIONS - SAFETY RULES

This is the safety alert symbol. It is used to alert you to potential personal injury hazards. Obey all safety messages that follow this symbol to avoid possible injury or death.

The safety alert symbol (▲) is used with a signal word (**DANGER, CAUTION, WARNING**), a pictorial and a safety message to alert you to hazards.

DANGER indicates a hazard that, if not avoided, will result in death or serious injury.

WARNING indicates a hazard that, if not avoided, could result in death or serious injury.

CAUTION indicates a hazard that, if not avoided, might result in minor or moderate injury.

NOTICE indicates a situation that could result in equipment or property damage.

IMPORTANT SAFETY INSTRUCTIONS - SAVE THESE INSTRUCTIONS

WARNING – When using this product, the following precautions should always be observed and adhered to.

1. Read all instructions before using the product.
2. Know how to stop the product quickly. Be thoroughly familiar with the controls of this air compressor as well as any tools that it may be attached to.
3. Stay alert. Watch what you are doing.
4. Do not operate the product when fatigued or under the influence of alcohol or drugs.
5. Keep operating area clear of other people and animals. Especially children.
6. Do not overreach or stand on unstable support. Instead, keep solid footing and balance at all times.
7. Follow the maintenance instructions specified in the manual.
8. Never modify or remove any components of the air compressor. This may expose moving parts or electrical components that can cause injury.



⚠️ WARNING - PERSONAL SAFETY

- **ALWAYS** wear correct personal protection equipment as needed for the task at hand and with the air tools and accessories being used.
- **ALWAYS** wear safety goggles for eye protection. Other protective equipment such as hearing protection, steel toe boots, safety apparel, work gloves and face shield are all recommended.

⚠️ DANGER – AIR TANK

- The air tank becomes a pressurized vessel when in use. Always treat it with caution and respect because severe damage can cause ruptures that may lead to explosive fragments.
- **NEVER** attempt to repair or make modifications to the air tank or it's attached components. Welding, drilling or any other modifications may weaken the tank, which may result in damage from rupture or explosion.
- **NEVER** remove or attempt to adjust the pressure switch, safety valve, or other factory set operating pressures.
- **ALWAYS** drain liquid from air tank daily, or after each use. Failure to drain the tank will cause rust from moisture to build which will weaken the tank and lead to rupture or explosion failures,
- **NEVER** use an air compressor with visible damage. Including, but not limited to; dents, cracks, rust or bulges. Visible flaw is an immediate safety concern.

⚠️ WARNING – FIRE

- Avoid dangerous environments. Do not use compressor near gasoline or flammable materials. Normal sparking of the motor or from grinding metal could ignite fumes.
- **NEVER** spray flammable materials in the vicinity of the air compressor because it may be an ignition source.

⚠️ WARNING– UNBREATHABLE AIR

- **NEVER** use this air compressor as a source for breathable air.
- This air compressor is not designed, to supply breathable quality air. Air produced by this unit may contain toxic fumes or lack sufficient oxygen levels to maintain life.

⚠️ WARNING- ELECTRIC SHOCK KICKBACK

- This air compressor is powered by electricity and should never be used without properly grounded electrical connections.
- **NEVER** expose to water or use in wet or damp conditions.
- **NEVER** use wet hands to plug in the power cord.
- **NEVER** use a damaged or modified cord or plug.

⚠️ WARNING – PRESSURIZED AIR

- **NEVER** direct compressed air at people or pets. Extreme caution is required with air nozzles that can discharge a concentrated stream of air.
- Be aware of loose debris or dirt that can be dislodged by pressurized air and become projectiles that can cause injury or damage.
- **ALWAYS** wear eye protection when using an air compressor.

⚠ WARNING – AIR TOOLS AND ACCESSORIES

- **NEVER** exceed the pressure rating on any air tools, spray guns, accessories or inflatables. Excessive pressure can cause failure or explosion resulting in injury.
- **ALWAYS** be familiar with the air tools and accessories that are being used. Read the owner's manual and be familiar with the operation and function of the air tools and accessories.
- Inspect the air hoses before use. Be aware of any damage which can lead to ruptures. Do not twist, bend, know, or modify hose. Do not wrap hose around body.

⚠ CAUTION – HOT SURFACES

- Air compressors generate significant heat during normal operation that may cause serious burns. The compressor will remain hot for sometime after shutdown.
- **ALWAYS** assume the air compressor can be hot and handle carefully. Be especially careful around the pump, motor, and the related fittings and the connections.

⚠ CAUTION – OVERHEATING

- Do not let your air compressor overheat. Failure to do so will result in undue wear and tear, reduce life span, and can lead to component failure.
- Air compressor's motor are air-cooled. Always ensure that the machine is operated in a well-ventilated area where it can draw a steady supply of fresh air. The arrows below show an example of locations for air flow on an engine.
- Always maintain the air filter to ensure adequate air flow into the pump.

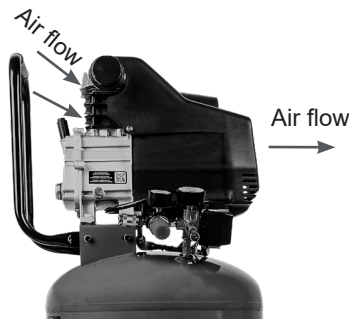
**⚠ CAUTION - DUTY CYCLE**

- The **Duty Cycle** is an expression of how much time an air compressor can be continuously ran without overheating.
- This air compressor has a 50% Duty Cycle, which means that over a ten minute time period it can safely operate for five minutes, and should rest for five minutes.
- The air compressor can be run straight without stopping, however, this will surpass the duty cycle and begin to create wear and tear from overheating.
- **ALWAYS** match the performance of the air compressor to what the demands of the tools and applications required.

Lubrication and Oil: This compressor requires 30 W non-detergent oil. The oil level can be checked on the sight glass. The oil level should be halfway up the sight glass.



Location of the Air Compressor: The air compressor should always be located in a clean, dry, and well-ventilated environment. The unit should have at minimum, 30cm of space on each side. The air filter intake should be free of any debris or obstructions. Check the air filter on a daily basis to be sure it is clean and in working order.

Extension Cords: We do not recommend the use of an extension cord with this product. This may result in the loss of power and overheating of the motor. An additional air hose should be used instead of an extension cord. However, if the use of an extension cord is unavoidable, use only UL listed wire extension cords that have three-pronged grounding type plugs and three prong receptacles that accept the tool's plug. Improper use of extension cords may cause inefficient operation of your compressor, which can result in overheating.

Be sure your extension cord is rated to allow sufficient flow to motor. Refer to the guide for minimum gauge required for extension cords.

EXTENSION CORD LENGTH	WIRE SIZE (A.W.C.)
Up to 25 Feet	14
26 to 50 Feet	12
51 to 100 Feet	10

Use of an extension cord heavy enough to carry the current the tool will draw is very important. Especially when the power source is of great distance. An extension cord that is insufficient will cause a drop in line voltage, resulting in power loss and causing the motor to overheat.

Guard against electrical shock. Avoid body contact with grounded surfaces such as pipes, radiators, ovens, stoves, and refrigerator enclosures. If not properly grounded, this power tool can incur the potential hazard of electrical shock, particularly when used in damp locations. If an electrical shock occurs, there is the potential of a secondary hazard such as your hands contacting an operating air tool.

Grounding Instructions: This product should be grounded. In the event of an electrical short circuit, grounding reduces the risk of electric shock by providing an escape wire for the electric current. This product is equipped with a cord having a grounding wire with an appropriate grounding plug. The plug must be plugged into an outlet that is properly installed and grounded in accordance with all local codes and ordinances. Check with a qualified electrician or service personnel if these instructions are not completely understood or if in doubt as to whether the tool is properly grounded.

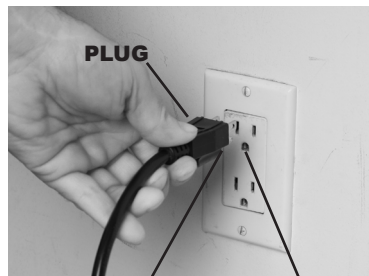

1. Remove the air compressor and all items from the packaging.

2. Slide the handle into position on the unit and use the fasteners to secure the handle into place.



3. Use the axle bolts and nuts to mount the wheels into place on the unit.



4. Thread the bolts through the rubber feet and then fasten the bolt on to the frame.



5. Thread the air filter into place on the air compressor.



6. Your unit is now ready to be used.

LUBRICATING OIL

**THIS AIR COMPRESSOR PUMP REQUIRES 30W NON-DETERGENT OIL.
CHECK THE DIPSTICK BEFORE EACH USE.**

TO BREAK IN, ON THE FIRST USE, OPEN THE DRAIN VALVE SO IT CAN'T BUILD PRESSURE AND RUN THE AIR COMPRESSOR FOR 10 MINUTES.

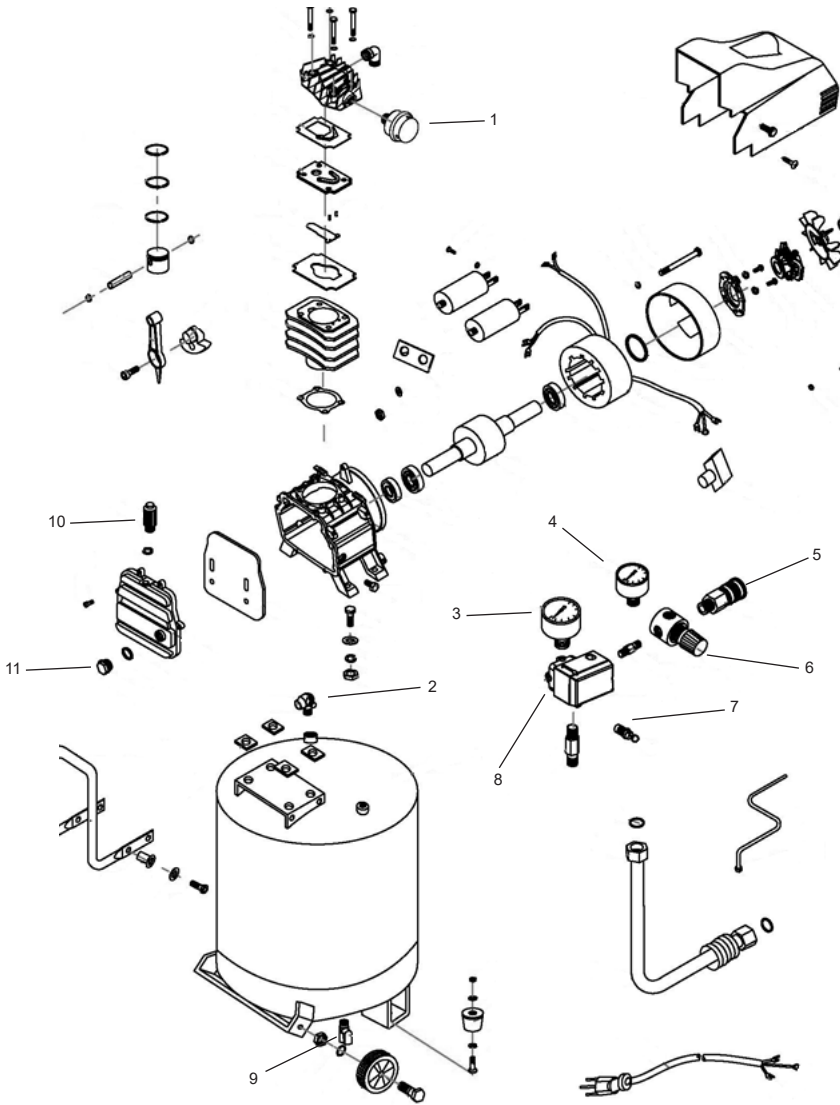

- | | |
|-----------------------------|-------------------------|
| 1. Air Filter | 7. Safety Valve |
| 2. Check Valve | 8. Pressure Switch |
| 3. Reservoir Pressure Gauge | 9. Air Tank Drain Valve |
| 4. Line Pressure Gauge | 10. Oil Breather Cap |
| 5. Outlet Coupler | 11. Oil Level Dipstick |
| 6. Pressure Regulator | |

Break-In Procedure. On first start-up, check the oil level, open the tank drain valve and let the air compressor run for 10 minutes. With the tank drain valve open, it will not be able to build up pressure. Once the 10 minutes have elapsed, switch off the air compressor. The break-in procedure is now complete and the air compressor can be used as normal.

Start-Up Procedure

1. Set the On/Off switch to the off position.
2. Visually check for any damage or obstruction.
3. Close the drain valve.
4. Plug the power cord into the proper receptacle.
5. Turn the On/Off switch to the On position and the compressor should start.
6. The machine will start and begin to build air pressure.
7. Adjust the regulator to a PSI setting that is recommended for your application.
8. The air compressor is now ready for use.

⚠ WARNING Improper installation of the grounding plug can result in a risk of electric shock. If repair or replacement of the cord or plug is necessary, do not connect the grounding wire to either flat blade terminal. The wire with insulation having an outer surface that is green with or without yellow stripes is the grounding wire. Check with a qualified electrician or serviceman if the grounding instructions are not completely understood, or if in doubt as to whether the product is properly grounded. Do not modify the plug provided; if it will not fit the outlet, have the proper outlet installed by a qualified electrician.

Shut-Down Procedure

1. Set the Auto-On/Off lever to the Off position.
2. Set the outlet pressure to zero on the regulator.
3. Unplug the power cord from the receptacle.
4. Remove any air tools or accessories.
5. Open the drain valve allowing air to bleed from the tank. After all of the air has bled from the tank, close the drain valve to prevent debris buildup in the valve. Water that remains in the tank during storage will corrode and weaken the air tank, which could cause the tank to rupture. To avoid serious injury, be sure to drain the tank after each use or daily.

⚠ CAUTION When draining the tank, always use ear and eye protection. Drain the tank in a suitable location; condensation will be present in most cases of draining.

MAINTENANCE

ITEM	ACTION	INTERVAL
Overall unit	Visual check	Every use
Oil Level	Sight glass visual check	Every Use
Tank safety valve	Feel for leaking air	Every use
Air filter	Visual check	Every use
Air fittings	Physical test	Every use
Air gauges	Visual check	Every use

PROBLEM	CAUSE	SOLUTION
Motor does not start	Power cord not plugged in.	Plug into proper outlet.
	Outlet not working.	Check outlet fuse and reset Plug into a different outlet.
	Cord damaged.	Repair or replace.
Motor hums, but does not start	Low voltage supply.	Check outlet/circuit. Use a dedicated circuit.
	Using an extension cord.	Remove extension cord and plug directly into wall.
Continual pressure drop from tank when not in use	Tank drain valve open.	Close drain valve.
	Fittings leaking.	Check fittings. Tighten or replace as necessary.
	Safety valve leaking.	Replace.
	Air leak at check valve	Drain tank, replace check valve
	Air leak between head and cylinder	Tighten head bolts. If still leaking, contact service centre.
Motor does not shut off	Pressure switch failure.	Manually turn off, or unplug to shutdown air compressor. Adjust or replace pressure switch. (contact service center)
	Air leaking.	Located air leak and fix.
Rapid pressure drop reading on air gauge	Air tool usage.	This is normal.
	Large air leak.	Check 'Continual pressure drop from tank when not in use' problem.
Excessive moisture in the air line	Water in the air tank.	Open tank drain valve to drain water. This should be done after every use.
	Over using air compressor	If the air compressor is using non-stop, it will build heat which will draw moisture. This is over doing the Duty Cycle and needs to be avoided. A larger air compressor to meet demand would be needed.
The compressor does not reach maximum pressure	Air leak in system	Located air leak and fix
	Air coming out of the air filter	Compressor head gasket broken or faulty valve. Contact service centre.

Pure Power Equipment warrants the original retail purchaser that this air compressor is free from defects in material and workmanship for the periods set forth below. If defects are found in Pure Power Equipment products within the limitations outlined in this warranty statement, Pure Power Equipment, at its sole discretion, will repair or replace the product free of charge.

The warranty coverage begins on the date of purchase by the end-user. Valid proof of purchase must be presented with the warranty claim.

- Pure Power Air Compressors 1 Year

This warranty is limited to defects that occurred during regular operational use. This warranty does not cover failures due to lack of service, negligence, abuse or misuse. Including, but not limited to, freezing damage, alterations, chemical deterioration, scale build-up, rust, corrosion, thermal shock, thermal expansion, transportation damage, oil changes, valve adjustments, lack of maintenance, or using incorrect repair parts. Furthermore, using the wrong power supply is considered a form of misuse.

This warranty also does not cover normal wearing items such as o-rings, valves, seals, filters, spark plugs or packings. These are considered to be maintenance items.

Pure Power Equipment expressly disclaims liability for injuries to persons or property or for incidental damages, rental loss, time loss, transportation costs, or consequential damages. It is the buyer's responsibility to ensure the correct installation and application of the product purchased.

THE WARRANTY CONTAINED HEREIN IS IN LIEU OF ALL OTHER WARRANTIES, EXPRESS OR IMPLIED, INCLUDING ANY IMPLIED WARRANTY OR FITNESS FOR A PARTICULAR PURPOSE. Pure Power Equipment does not authorize any of its dealers, service centers, agents, employees or any other party to expand, extend or modify the scope of this warranty in any manner on behalf of Pure Power Equipment.

To obtain warranty, the claimant must take the product, with their original proof of purchase, to an authorized service center.

Pure Power service centers are associated with BE Power Equipment service centers that can be found on the website:

<https://www.bepowerequipment.com/service-centers>

If you cannot resolve the warranty claim satisfactorily, contact the Pure Power Equipment Warranty Department (1-866-850-6662). Be prepared with details of the defect, proof of purchase, model, and the pressure washer's serial number.





DO NOT RETURN THIS PRODUCT TO THE RETAILER
CONTACT OUR CUSTOMER SERVICE if you need assistance with
the assembly, operation, or if you experience a problem with your air
compressor, please call 1-866-850-6662
Monday - Friday. 8AM to 430PM PST.

 **PUREPOWEREQUIPMENT.COM**